

# Operating Manual

Mark Levinson®  
N°29  
Dual Monaural  
Power Amplifier

**WARNING:** TO REDUCE THE RISK OF FIRE OR ELECTRIC SHOCK,  
DO NOT EXPOSE THIS APPLIANCE TO RAIN OR MOISTURE.

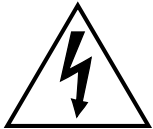
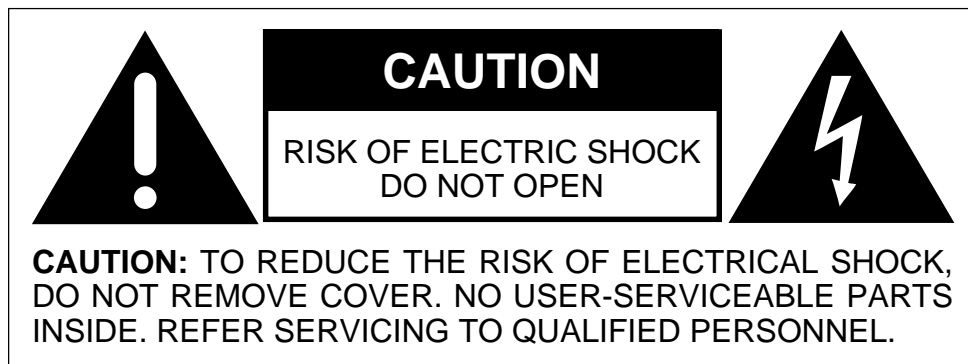

The lightning flash with arrowhead symbol, within an equilateral triangle, is intended to alert the user to the presence of uninsulated “dangerous voltage” within the product’s enclosure that may be of sufficient magnitude to constitute a risk of electric shock to persons.



The exclamation point within an equilateral triangle is intended to alert the user to the presence of important operating and maintenance (servicing) instructions in the literature accompanying the appliance.

# Important safety instructions

Please read all instructions and precautions carefully and completely before operating your N° 29 Dual Monaural Power Amplifier.

1. **ALWAYS** disconnect your entire system from the AC mains before connecting or disconnecting any cables, or when cleaning any component.
2. This product is equipped with a three-conductor AC mains power cord which includes an earth ground connection. To prevent shock hazard, all three connections must **ALWAYS** be used. If your electrical outlets will not accept this type of plug, an adapter may be purchased. If an adapter is necessary, be sure it is an approved type and is used properly, supplying an earth ground. If you are not sure of the integrity of your home electrical system, contact a licensed electrician for assistance.
3. AC extension cords are not recommended for use with this product. If an extension cord must be used, be sure it is an approved type and has sufficient current-carrying capacity to power this product.
4. **NEVER** use flammable or combustible chemicals for cleaning audio components.
5. **NEVER** operate this product with any covers removed.
6. **NEVER** wet the inside of this product with any liquid.
7. **NEVER** pour or spill liquids directly onto this unit.
8. **NEVER** block air flow through ventilation slots or heatsinks.
9. **NEVER** bypass any fuse.
10. **NEVER** replace any fuse with a value or type other than those specified.
11. **NEVER** attempt to repair this product. If a problem occurs, contact your Mark Levinson® dealer.
12. **NEVER** expose this product to extremely high or low temperatures.
13. **NEVER** operate this product in an explosive atmosphere.
14. **ALWAYS** keep electrical equipment out of the reach of children.

*Thank you for choosing the Mark Levinson® N°29 Dual Monaural Power Amplifier.*

*A great deal of effort went into the design and construction of this precision device. Used properly, it will give you many years of enjoyment.*

# Table of contents

<b>Unpacking and placement</b> .....	<b>1</b>
Unpacking .....	1
Placement .....	1
Ventilation .....	1
Custom installations .....	1
<b>Voltage selection</b> .....	<b>2</b>
<i>Figure 1: Rear-panel label</i> .....	2
<b>Signal connections</b> .....	<b>3</b>
Connectors .....	3
Cables .....	3
Connection methods and operating modes .....	3
Single-ended normal (non-inverting) operation .....	3
<i>Figure 2: Connections for single-ended normal (non-inverting) operation</i> .....	3
<i>Figure 3: Female input connector</i> .....	4
Single-ended inverting operation .....	4
<i>Figure 4: Connections for single-ended inverting operation</i> .....	4
Balanced normal (non-inverting) operation .....	5
<i>Figure 5: Connections for balanced normal (non-inverting) operation</i> .....	5
<b>Speaker connections</b> .....	<b>6</b>
Speaker cables .....	6
Lug connection .....	6
<i>Figure 6: Spade and hook lugs</i> .....	6
Pigtail connection .....	6
<i>Figure 7A: Pigtail connection</i> .....	6
<i>Figure 7B: Pigtail connection</i> .....	7
<i>Figure 7C: Pigtail connection</i> .....	7
Connecting the speakers .....	7
<b>Power connection</b> .....	<b>8</b>
Connecting the AC power cord .....	8
<i>Figure 8: AC power cord polarity</i> .....	8
Performance tips .....	8
Protection circuitry .....	8
<b>Bridged operation</b> .....	<b>9</b>
Balanced bridged operation .....	9
<i>Figure 9: Connections for balanced bridged operation</i> .....	9
<i>Figure 10: Balanced bridging cable</i> .....	10
Single-ended bridged operation .....	10
<i>Figure 11: Connections for single-ended bridged operation</i> .....	10
<i>Figure 12: Single-ended bridging cable</i> .....	11
<b>Care and maintenance</b> .....	<b>12</b>
Cleaning .....	12
Fuses .....	12
<b>Specifications</b> .....	<b>13</b>
<b>Dimensions</b> .....	<b>14</b>
<i>Figure 13A: Dimensions, N°29, top view</i> .....	14
<i>Figure 13B: Dimensions, N°29, side view</i> .....	14

# Unpacking and placement

## Unpacking

Unpack your N°29 amplifier and keep all packing materials for future transport.

### PRECAUTION

***To avoid damaging the connectors on input cables attached to the rear panel, NEVER rest the N°29 on the rear panel, and NEVER tip it back in a way that would put stress on these connectors.***

Carefully inspect your N°29 for damage and flaws. If you find any, see your Mark Levinson dealer immediately.

## Placement

To keep speaker cables as short as possible, place the N°29 as close to the loudspeakers as practical.

Place the N°29 at least three feet from the turntable and preamplifier. Otherwise, the N°29 may induce hum into these sensitive components.

## Ventilation

The N°29 may be placed in a cabinet or on a shelf, but adequate ventilation must be provided to prevent overheating. The clearance provided by the unit's feet must be maintained to ensure unrestricted air flow across the bottom of the chassis. (Placing the N°29 on carpeting, for example, may prevent adequate air circulation.) Clearance above the unit must also be maintained to allow air circulation and to prevent heat buildup.

The N°29 incorporates thermal sensors located near each group of output devices. If the internal heatsink temperature becomes excessive, these sensors will shut off the amplifier before damage results. After a brief cooling period, the amplifier can be reactivated via the front-panel switch. If this occurs regularly during normal use, it's an indication that the ventilation provided for the amplifier is inadequate. If there's adequate ventilation and the problem continues, see your Mark Levinson dealer immediately.

## Custom installations

For those involved in custom installations and cabinetry, this information may be useful:

- All temperature measurements are made at the bottom of the internal heatsink, 2 inches above the chassis floor.
- Normal heatsink temperature at idle after warmup with unrestricted airflow at 22°C (72°F) ambient temperature: 35°C (95°F).
- Maximum permissible heatsink temperature before thermal protection is activated: 80°C (176°F).

Drawings are included in this manual to facilitate special installations and custom cabinetry (see "Dimensions").

### PRECAUTION

***For your protection, review "Important safety instructions" before you install your N°29.***

# Voltage selection

The N°29 is factory-set (internally) for 100V, 120V, 200V, 220V, or 240V AC mains operation. Check that the label on the rear panel of the amplifier indicates the correct AC operating voltage for your location.

Figure 1: Rear-panel label

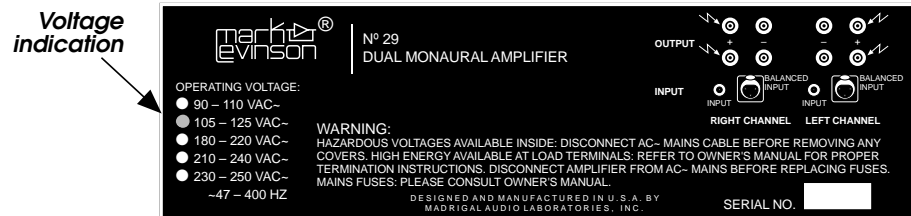

If the voltage indicated is incorrect, see your Mark Levinson dealer.

If you wish to change the AC operating voltage of your N°29, see your Mark Levinson dealer.

A N°29 may be powered by a 15-ampere AC mains line. If other devices are also powered from the same AC feed, their additional power consumption must be considered.

The N°29's fuses are located on the rear panel. Replace the fuses with the same type only.

## PRECAUTION

**ALWAYS** remove the AC cord before removing the fuses.

# Signal connections

**Connectors** The N°29 incorporates RCA-type and XLR-type connectors for audio signal input.

The Madrigal-designed RCA-type connectors used for single-ended audio interconnection are a great improvement over ordinary RCA-type connectors. The gold-plated XLR-type connectors employed are of European design, and are made to professional application standards.

**Cables** For connecting the N°29 to a preamplifier, we recommend Madrigal Audio Laboratories HPC Interconnect Cable. HPC is available in various lengths, pre-terminated with RCA, XLR, and Camac connectors. For more information, see your Mark Levinson dealer.

**Connection methods and operating modes** The N°29 can be operated in either single-ended or balanced mode. In each of these modes, the N°29 can be operated either normally (non-inverting) or inverting.

This manual describes the connections for single-ended normal (non-inverting), single-ended inverting, and balanced normal (non-inverting) operation. If you have questions about these or other methods of signal connection, see your Mark Levinson dealer.

## PRECAUTION

**Before making any signal or speaker connections, make sure that the N°29 is disconnected from your preamplifier and from the AC mains.**

### Single-ended normal (non-inverting) operation

Typical audio systems require that the amplifier be of the non-inverting type. This means that the output signal of the amplifier will be in phase with the input signal.

For this type of operation, connect the main outputs of the preamplifier to the appropriate (left and right channel) RCA-type inputs (non-inverting) on the rear panel of the N°29. Be sure that the shorting strap is inserted into the XLR-type connectors between Pins 1 and 3.

Figure 2: Connections for single-ended normal (non-inverting) operation

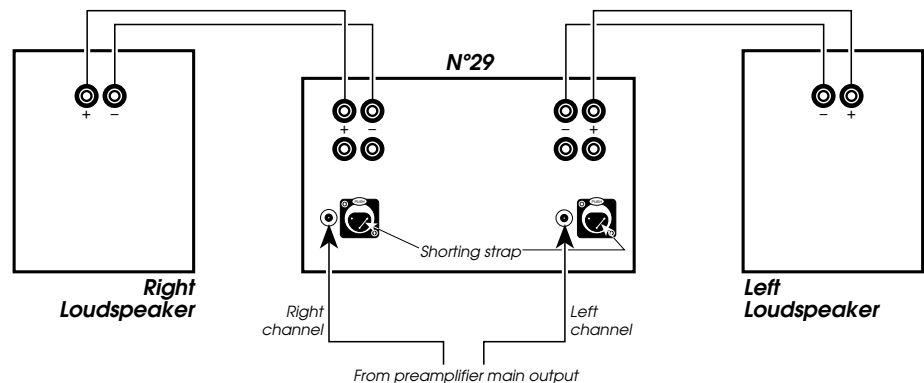



**Single-ended inverting operation**

Inverting operation should be used if a phase reversal is required. In this mode of operation, the output signal of the amplifier will be 180° out of phase with the input signal. This may be required if one component in the system inverts the signal and absolute phase at the loudspeaker is desired.

For inverting operation, the main output cables of the preamplifier must be connected to the XLR-type inputs on the rear panel of the N°29. The pin assignments of these connectors are:

Figure 3: Female input connector

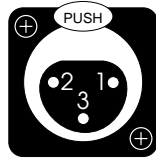

- Pin 1: Signal ground
- Pin 2: Signal + (non-inverting)
- Pin 3: Signal - (inverting)
- Connector ground lug: chassis ground

Connect the XLR-type male line-mount connector to the preamplifier main output cable so that signal "hot" (+) connects to Pin 3 and signal ground connects to Pin 1. Be sure to also connect Pin 2 to Pin 1 inside the XLR-type male line-mount connector with a piece of copper buss wire (or similar material) at the amplifier end of the cable.

**Note:** If you prefer not to connect Pin 2 to Pin 1 inside the XLR-type male line-mount connector, pre-shorted RCA-type input connectors are available from your Mark Levinson dealer. Insert one of these connectors into each of the RCA-type inputs (non-inverting) on the rear panel of the N°29.

After completing the cables, connect the main outputs of the preamplifier to the left- and right-channel XLR-type inputs on the rear panel of the N°29. Be sure to remove the shorting strap between Pins 1 and 3 before inserting the output cable connectors.

Figure 4: Connections for single-ended inverting operation

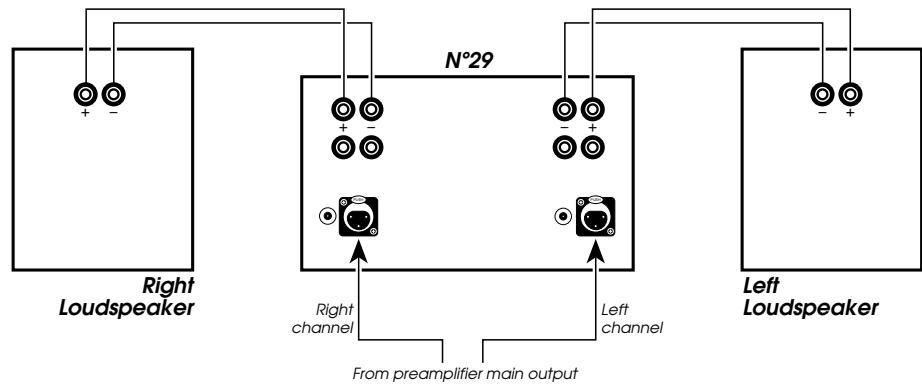

**Balanced normal  
(non-inverting) operation**

If your preamplifier is equipped with a balanced main output, it's best to wire the N°29 for balanced operation, particularly if long cable lengths are required between the preamplifier and the N°29. (See Figure 3 for the pin assignments of the N°29's XLR-type inputs.)

Connect the XLR-type male line-mount connector to the preamplifier, carefully observing pin assignments. (Refer to your preamplifier's operating manual to verify that the pin assignments of its output correspond to the diagram above. If they don't, wire the connector so that the appropriate output pin connects to the equivalent input pin.)

When complete, connect the main outputs of the preamplifier to the left- and right-channel XLR-type inputs on the rear panel of the N°29. Be sure to remove the shorting strap between Pins 1 and 3 before inserting the output cable connectors.

**Note:** For proper balanced operation, no connector (pre-shorted or otherwise) should be inserted into the RCA-type inputs on the rear panel of the N°29.

Figure 5: Connections for balanced normal (non-inverting) operation

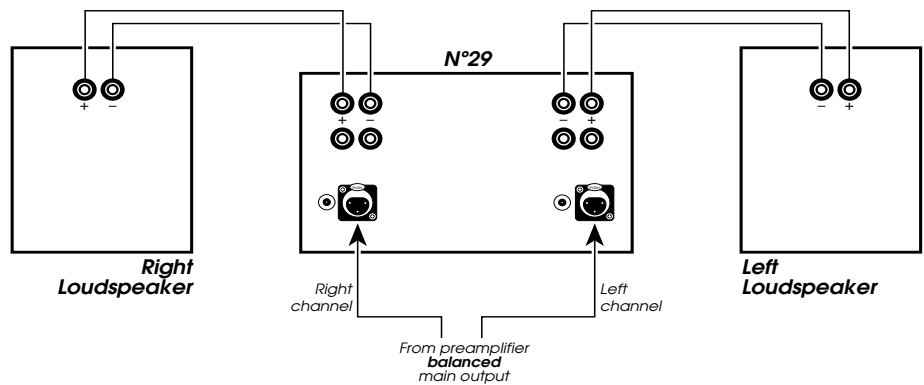

# Speaker connections

## PRECAUTION

**NEVER** connect the N°29's output terminals to any device other than a loudspeaker.

## PRECAUTION

**NEVER** short-circuit the amplifier output terminals.

## PRECAUTION

**NEVER** connect the left-channel output terminals to the right-channel output terminals.

### Speaker cables

The N°29 is equipped with gold-plated, high-current, five-way binding posts for output termination to a loudspeaker system. To take full advantage of the sonic quality of the N°29, we recommend using high-quality speaker cable. See your Mark Levinson dealer for recommendations.

### Lug connection

There are two recommended methods for connecting speaker cables to the N°29. A high-quality spade- or hook-type lug, soldered to the cable, is best.

Figure 6: Spade and hook lugs



We confidently recommend Madrigal binding-post lugs, made of oxygen-free copper with gold-over-silver plating. These lugs are available for round cable; see your Mark Levinson dealer for more information.

Many lug connectors are designed to be crimped onto the cable. However, soldering will ensure a better electrical connection.

**Note:** If you have no experience in soldering, see your Mark Levinson dealer for assistance.

### Pigtail connection

The "pigtail" is another method of connection which uses a short piece of 14-gauge wire soldered to the speaker cable. The other end of this 14-gauge wire is inserted through the hole in the five-way binding posts on the rear panel of the N°29.

1. Begin with 3" of 14-gauge copper wire.
2. Strip 5/8" of insulation from one end, and strip 1/2" of insulation from the opposite end:

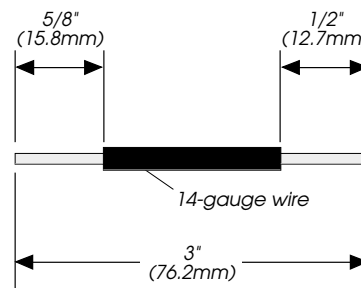
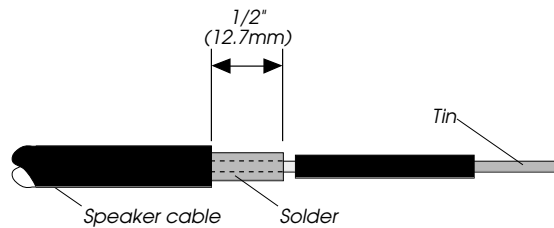

Figure 7A: Pigtail connection

- Strip 1/2" of insulation from the speaker cable.
- Gently slide the (5/8") bare end of the 14-gauge wire into the center of the bare speaker cable (be careful not to spread the individual wires of the speaker cable).

Figure 7B: Pigtail connection



- Solder this connection. A high-wattage soldering gun may be necessary to provide adequate heat.
- Lightly "tin" the remaining (1/2") bare end of the 14-gauge wire.
- Gently slide a 1" length of shrink tubing over the connection and heat to shrink. (Color-coded shrink tubing is available for polarity identification.)

Figure 7C: Pigtail connection

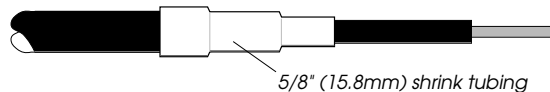

- Follow this procedure for the remaining speaker connections.

Depending upon the type of speaker terminal, this procedure may also be used for the speaker end of the cable.

### Connecting the speakers

When the speaker cables are complete, connect the left-channel + (positive or red) output post of the N°29 to the + (positive or red) input terminal of the appropriate loudspeaker.

Connect the left-channel - (negative or black) output post of the N°29 to the - (negative or black) input terminal of the appropriate loudspeaker.

Repeat this procedure for the right channel.

**Note:** The N°29 provides two sets of output posts to accommodate the increasing number of loudspeakers that call for **bi-wiring**. For specific instructions on bi-wiring, refer to your loudspeaker owner's manual or see your Mark Levinson dealer.

For the best sonic performance, we recommend against using the two sets of output posts to connect two sets of full-range loudspeakers. Doing so, however, won't damage the N°29, as long as the total load impedance is at least 2Ω.

# Power connection

After making your loudspeaker connections, apply power to your preamplifier and allow it to stabilize. (Mark Levinson preamplifiers, for example, require about one minute to stabilize.)

## Connecting the AC power cord

Connect the AC power cord (included in the accessory pack) to the AC connector on the rear panel of the N°29, then to the AC mains outlet.

Figure 8: AC power cord polarity

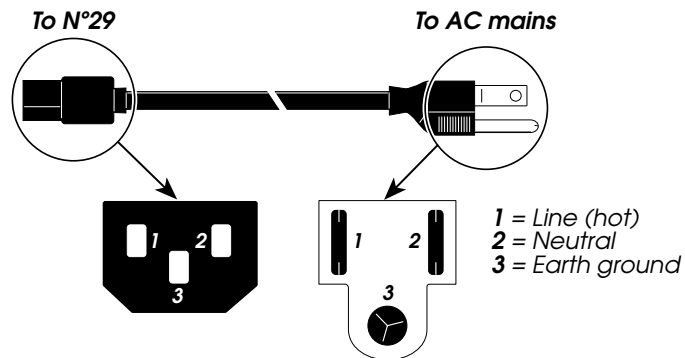

Turn on the N°29 by setting the power switch on the front panel to the "I" (on) position.

**Note:** You may hear a transient "click" or "pop" through your speakers a few seconds after you operate the N°29's power switch. This noise is normal and won't damage your speakers.

## Performance tips

The N°29 won't achieve its sonic potential right away — its sonic performance is close to the optimum after about 100 hours of use. For the best performance, you may leave your N°29 powered at all times, except when you won't be using it for a long period (see "Important Safety Instructions").

The N°29 is designed to be "power-cycled" (that is, turned on and off) without affecting its longevity. After the amplifier is turned on after being left unpowered, allow for about one hour of warmup before expecting optimal sonic performance.

## Protection circuitry

Under certain conditions (an electrical malfunction or inadequate ventilation), the N°29's protection circuitry may activate, turning off the amplifier before damage results. When this happens, the power switch on the front panel will be set automatically to the "O" (off) position. After a brief cooling period, you can reactivate the amplifier by setting the power switch to the "I" (on) position.

If this occurs regularly during normal use, see your Mark Levinson dealer immediately.

**Note:** While the protection circuitry is active, the power switch won't stay in the "I" (on) position. If, after the amplifier has cooled, the power switch still won't engage, the protection circuitry still detects a malfunction; see your Mark Levinson dealer immediately.

# Bridged operation

When greater power output is desired, the N°29 may be bridged for monophonic operation into load impedances of at least  $2\Omega$ .

**Note:** Make sure the loudspeaker is rated to handle high power levels. For example, a bridged N°29 driving an  $8\Omega$  loudspeaker is capable of delivering 200W RMS.

## Balanced bridged operation

For the best bridged performance, we recommend balanced interconnection. If your preamplifier provides balanced output, follow the steps below.

Figure 9: Connections for balanced bridged operation

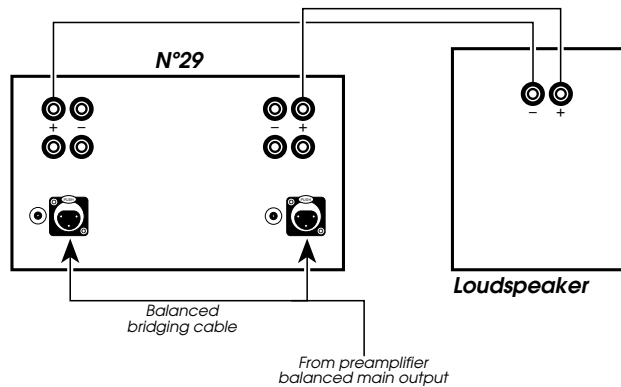

1. For balanced bridged operation, you'll need a special three-ended cable. You may fabricate such a cable according to Figure 10; it's also available through your Mark Levinson dealer as part of a balanced bridging kit.

**Note:** If fabricating the cable, be sure to use high-quality audio interconnect cable (such as Madrigal HPC).

Connect the bridging cable's female XLR-type connector to the appropriate channel of your preamplifier's balanced main output.

Figure 10: Balanced bridging cable

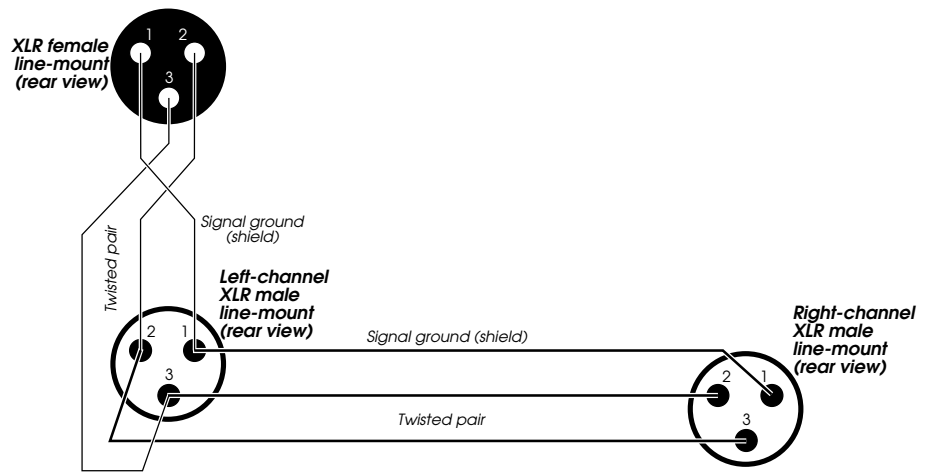

2. Connect the bridging cable's male XLR-type connectors to the N°29's left- and right-channel XLR-type input connectors, taking care to insert the correct cable end into its designated channel.
3. Connect the left-channel + (positive or red) output post of the N°29 to the + (positive or red) input terminal of the appropriate loudspeaker. Connect the right-channel + (positive or red) output post of the N°29 to the - (negative or black) input terminal of the same loudspeaker.
4. Repeat this procedure for the other N°29 to be bridged.

If your preamplifier provides only single-ended output, follow the steps below.

Figure 11: Connections for single-ended bridged operation

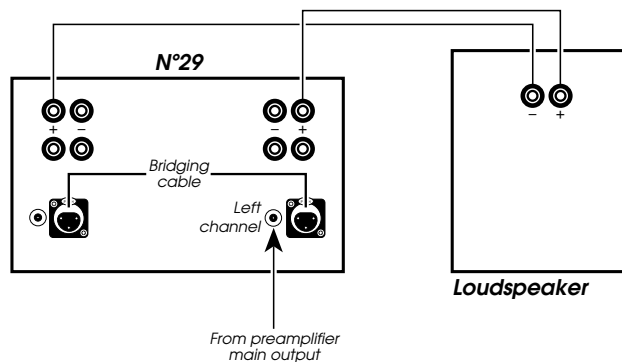

1. Connect the appropriate channel of your preamplifier's single-ended main output to the left-channel RCA-type input on the rear panel of the N°29.

2. Connect the bridging cable between the left- and right-channel XLR-type input connectors, taking care to insert the correct cable end into its designated channel. You may fabricate such a cable according to Figure 12; it's also available through your Mark Levinson dealer as part of a single-ended bridging kit.

**Note:** If fabricating the bridging cable, be sure to use high-quality audio interconnect cable (such as Madrigal HPC).

Figure 12: Single-ended bridging cable

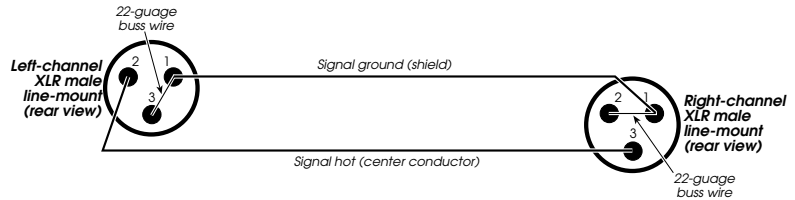

3. Connect the left-channel + (positive or red) output post of the N°29 to the + (positive or red) input terminal of the appropriate loudspeaker. Connect the right-channel + (positive or red) output post of the N°29 to the - (negative or black) input terminal of the same loudspeaker.
4. Repeat this procedure for the other N°29 to be bridged.



# Care and maintenance

**Cleaning** To remove dust from the cabinet of the N°29, use a feather duster. To remove dirt and fingerprints, use isopropyl alcohol applied to a soft cloth.

Poor connections cause sonic degradation. We recommend, therefore, that you clean all speaker connection with denatured alcohol at least once a year. Consult your Mark Levinson dealer for other ways to optimize connections.

**Fuses** The N°29's fuses are located on the rear panel. Replace the fuses with the same type only.

## PRECAUTION

**ALWAYS** remove the AC cord before removing the fuses.

# Specifications

---

*The correlation between published specifications and sonic quality is unreliable. A list of numbers reveals virtually nothing. All technical measurements must be subject to qualitative as well as quantitative interpretation.*

*Measurements of the N°29 yield excellent results by any standards. However, only those specifications that apply to the actual operation of the amplifier are included here.*

---

- **Rated power:** 50W minimum continuous sine wave power into 8Ω, with both channels driven from 20Hz to 20KHz with no more than 0.1% THD (FTC). 100W minimum continuous sine wave power into 4Ω with both channels driven from 20Hz to 20KHz with no more than 0.2% THD (FTC).
- **Peak output voltage:** 30 volts @ rated line voltage @ 8Ω
- **Frequency response:** (-3dB) 4Hz, 122KHz
- **Input impedance:** 50KΩ shunted by 1.5nF
- **Voltage gain:** 26dB
- **Power consumption:** Typically 100W @ idle, 200W @ rated power, 8Ω
- **Overall dimensions:** See "Dimensions"
- **Shipping weight:** 39.25 lbs. (17.8kg)
- **Connector complement:** Two RCA-type connectors  
Two XLR-type connectors  
Eight five-way binding posts  
One IEC mains connector

For more information, see your Mark Levinson dealer, or contact:

**Madrigal Audio Laboratories, Inc.**  
2081 South Main Street (Route 17), P.O. Box 781  
Middletown, Connecticut 06457 USA

Telephone (203) 346-0896  
(FAX (203) 346-1540

If purchased in North America, this Mark Levinson product's warranty is owner-transferable. Warranty conditions are valid only in the country where the product was originally purchased.

For warranty information and conditions on products purchased outside of North America, contact your local dealer or regional distributor.

# Dimensions

Figure 13A: Dimensions, N°29, top view

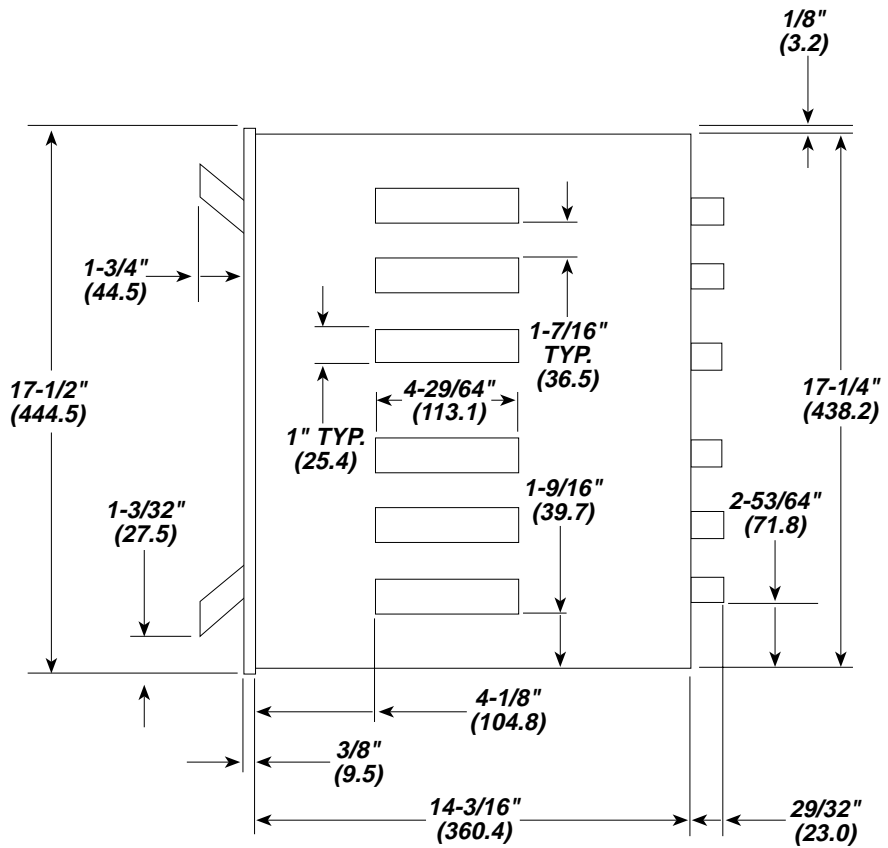
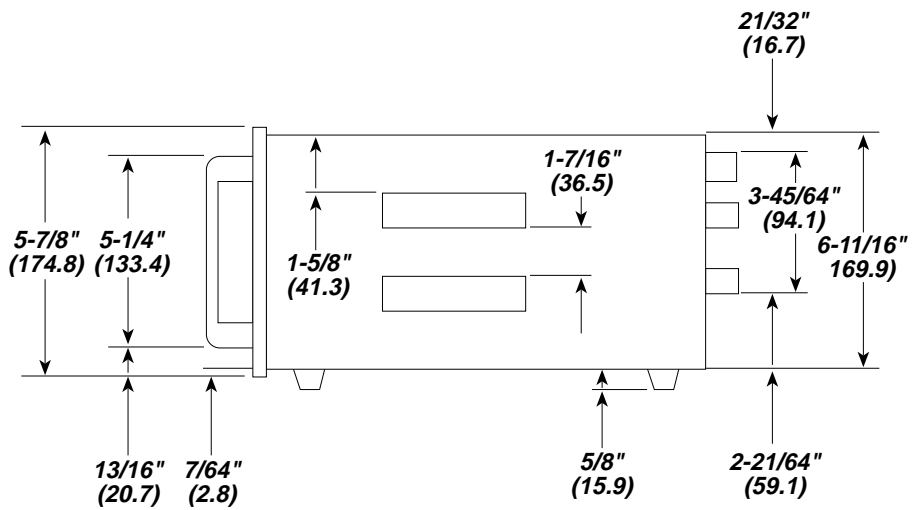

Figure 13B: Dimensions, N°29, side view



# MADRIGAL

MADRIGAL AUDIO LABORATORIES

2081 South Main Street, P.O. Box 781  
Middletown, Connecticut 06457 USA

Telephone: (203) 346-0896  
Fax: (203) 346-1540



is a registered trademark of Madrigal Audio Laboratories, Inc.